



Surface cleaning system AQUABLAST® cleaning line

Semi-automatic cleaning system with Aquablast® surface cleaner

Predictable cleaning time

Higher operational safety

Reduced energy consumption

Customizable

Simple and quick set-up

Hammelmann service worldwide

AQUABLAST® cleaning line

Product video on our website



A wide variety of components are exposed to massive load and dirt in professional industrial use. This leads to increased wear, often to a higher weight of the parts and an exchange of the material is necessary frequently. Regular cleaning of the elements noticeably extends the service life, handling is improved by the lower weight and physical stress is reduced.

The elements are usually cleaned manually with a high-pressure gun. A manual process that is time-consuming and certainly has the potential for injury. Hammelmann's unique cleaning line is a semi-automatic system that makes cleaning easier, faster and easier to plan. Occupational safety is significantly improved and the costs for wages and energy use are also reduced.

Your benefits

- Higher occupational safety both on the construction site as well as during cleaning
- Clean large areas quickly and easily
- Precise, more predictable time expenditure
- No time-consuming gun work
- Less energy consumption
- Lower cleaning costs due to lower wages
- More time for work, less effort for cleaning
- Less need for replacement

Feature set



External connection for blasting gun



Control of pressure and flow rate



Height and speed adjustment



The cleaning line is suitable for cleaning many elements in different shapes and sizes

The concept

The overall system is based on a modular concept and can be adapted to individual requirements with little effort. In advance, the necessary parameters for optimal cleaning are determined in close cooperation with the customer.

The cleaning line consists of taxiways, the cleaning chamber with spray bars and nozzles, baskets for storing the parts, the chain

conveyor, the pump unit for supplying high-pressure water and all the necessary control elements and sensors.

The elements to be cleaned are conveyed through the cleaning chamber in the baskets. The feed can be adjusted in a range from 0 – 90 mm / sec. The elements are cleaned at high pressure in the cleaning chamber.

The number of spray bars used is configured individually and determines the overall working width of the system.

The seamless height adjustment allows optimal adaptation to the parts to be cleaned.

Quick and easy set-up

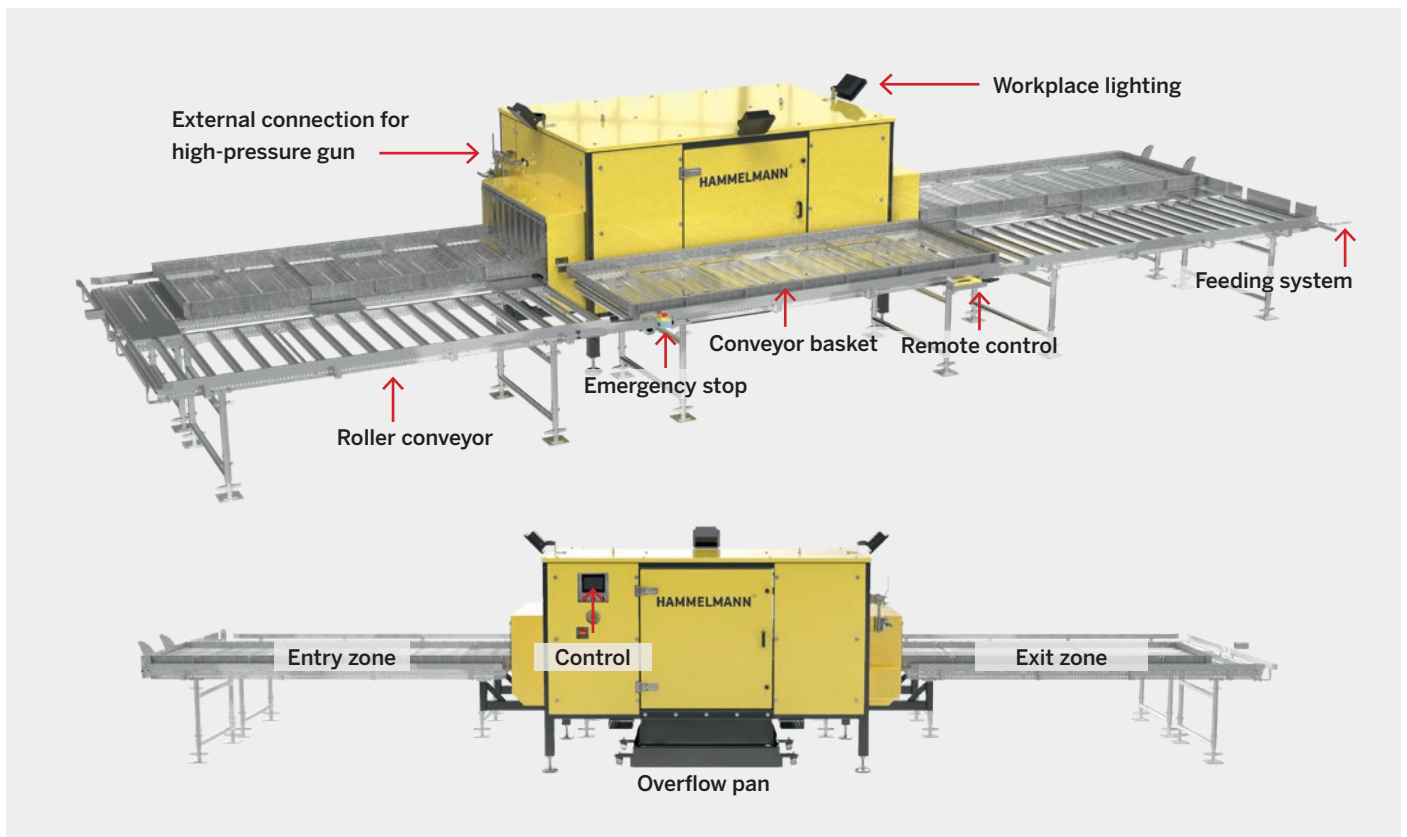
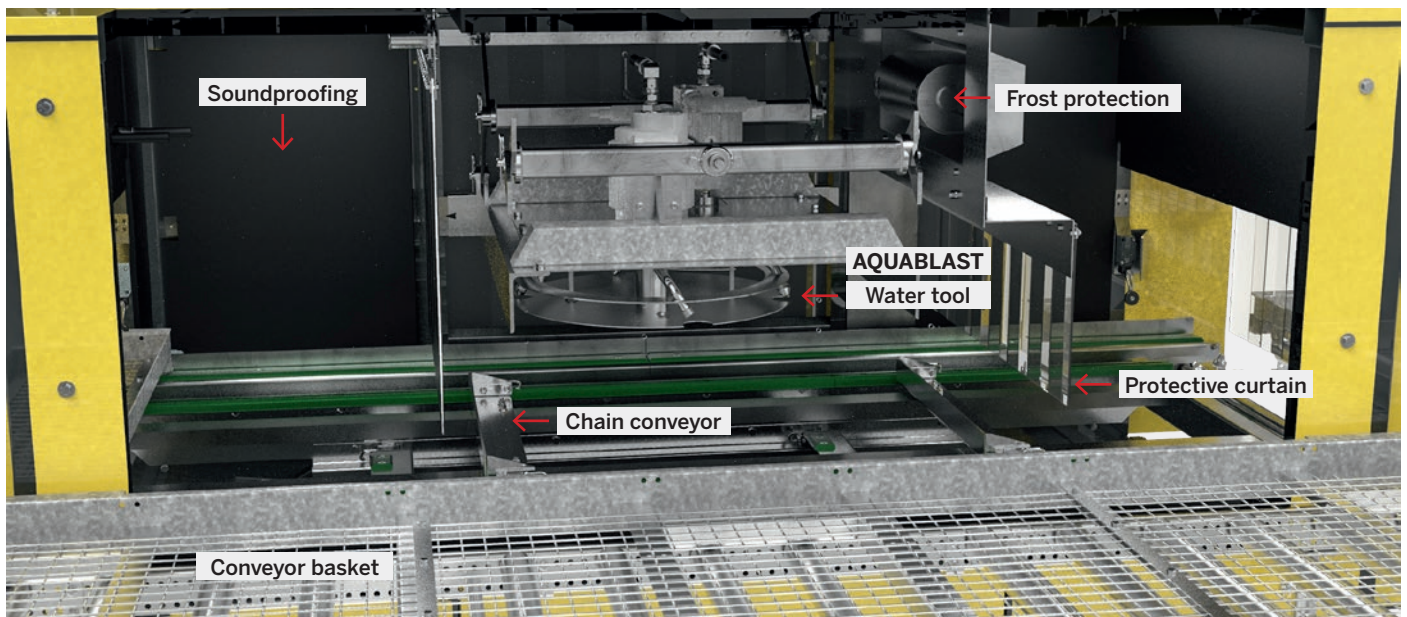

Performance data, exemplary:

- Length: 10 m
- Width: 3,2 m or 4,1 m
- Height: 1,95 m or 2,15 m
- Working width: 1 m or 1,5 m

Possible pump configuration

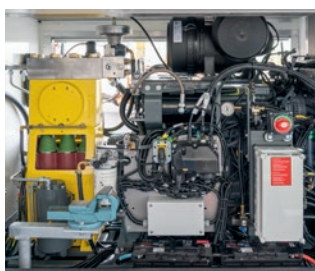

Flow rate	Operating pressure
up to 300 l/min	up to 3000 bar

The factory - Oelde



Certificates

DIN EN ISO 9001
DIN EN ISO 14001
DIN EN ISO 50001
BS OHSAS 18001
TÜV ATEX 2524 X
ASME-U
Achilles



Hammelmann service worldwide

Subsidiaries in USA, China, Australia, Spain, France, and Switzerland, and 40 agents and distributors worldwide



Hammelmann GmbH

Carl-Zeiss-Straße 6-8
59302 Oelde • Germany
mail@hammelmann.de

Tel.: (0) 25 22 / 76 - 0
Fax: (0) 25 22 / 76 - 140
www.hammelmann.com

